

Ø100 mm LED Traffic Lights
Model No.: TP100x2



Novel design with beautiful appearance
Low power consumption
High efficiency and brightness
Large viewing angle
Long lifespan: 80 000 hours
Multi-layer sealed and waterproof

Product Features

Visual distance: ≥ 300 m
Housing: Aluminum, Alloy steel,
Polycarbonate
Sun visor: Aluminum / Alloy steel
Exclusive optical lens and good
color uniformity

Long viewing distance
Wide temperature: $-40^{\circ}\text{C} \sim +80^{\circ}\text{C}$
CE, IP55, ITE Standard, RoHS,
TUV, UL, EMC, LVD, WEEE,
Swedish standard SS-EN 12368:2006

Technical Parameters:

Article Number	Color	LED Qty	Light Intensity	Wave Length	Viewing Angle L/R	Viewing Angle U/D	Power	Working Voltage	Housing Material
TP100x2	Red	45	$\leq 150\text{cd}$	$625 \pm 5 \text{ nm}$	30°	30°	5W	11-30VDC/VAC 85V-265VAC, 50/60HZ	Aluminum, Alloy steel, PC, UV resistant
	Green		$\leq 300\text{cd}$	$505 \pm 2 \text{ nm}$					

Packing Info:

Carton Size	QTY	GW	NW	Wrapper	Volume (m3)
0,32 * 0,22 * 0,23 m	2 pcs /carton box	2,7 kg	2,5 kg	K=K carton	0,016

Packing List:

Name	Light	L Bracket	Sun Visor	M4×10 Screw	Terminal Cover & Terminal Cover Gasket	Using Manual
Qty. (pcs)	2	2	2	4	1	1

Installation Sketch:

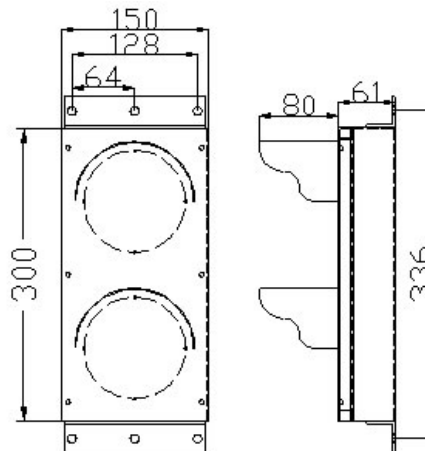

Address
Baiona AB
Hagagatan 34
113 47 Stockholm
Sweden
Phone
+46 (0)73-679 35 50

Company headquarters
Stockholm
Bank
Handelsbanken
IBAN
SE78 6000 0000 0005 9016 1881
BIC
HANDSESS

Bankgiro
5456-5197
Organization no
559243-2479
VAT number
SE559243247901
Holds F-tax certificate

Internet
www.ledochled.se
E-mail
info@ledochled.se
Terms & delivery conditions
www.ledochled.se/villkor

Installations:



Address
Baiona AB
Hagagatan 34
113 47 Stockholm
Sweden
Phone
+46 (0)73-679 35 50

Company headquarters
Stockholm
Bank
Handelsbanken
IBAN
SE78 6000 0000 0005 9016 1881
BIC
HANDSESS

Bankgiro
5456-5197
Organization no
559243-2479
VAT number
SE559243247901
Holds F-tax certificate

Internet
www.ledochled.se
E-mail
info@ledochled.se
Terms & delivery conditions
www.ledochled.se/villkor



Address
Baiona AB
Hagagatan 34
113 47 Stockholm
Sweden
Phone
+46 (0)73-679 35 50

Company headquarters
Stockholm
Bank
Handelsbanken
IBAN
SE78 6000 0000 0005 9016 1881
BIC
HANDSESS

Bankgiro
5456-5197
Organization no
559243-2479
VAT number
SE559243247901
Holds F-tax certificate

Internet
www.ledochled.se
E-mail
info@ledochled.se
Terms & delivery conditions
www.ledochled.se/villkor