

LED Warning Lights

Features:

- 1, Special design for zebra line pedestrian, with 505nm green light and 625nm red light, good color uniformity, soft, not dazzling. When the sun is strong, you can see the light with the maximum brightness. At night the brightness automatically dimming to 30% by light sensation.
- 2, Anti high strength compression and vibration: use 10mm frosted tempered glass, the surface is designed to prevent slippery; Own design of rubber spring for buffer the pressure when car running over the light.
- 3, The embedded parts easy for maintenance, only need to release the screw to replace the light.
- 4, IP67 waterproof Constant current power supply, response time <100ms, without delay, synchronized with pedestrian traffic lights;
- 5, Best heat sink with unique buried ventilation holes;
- 8, Novelty design with beautiful appearance, covered by stainless steel surface.
- 9, Length :1M/PCS, also can be customized,
- 6, Waterproof: IP67.
- 7, Warranty > 3 years.

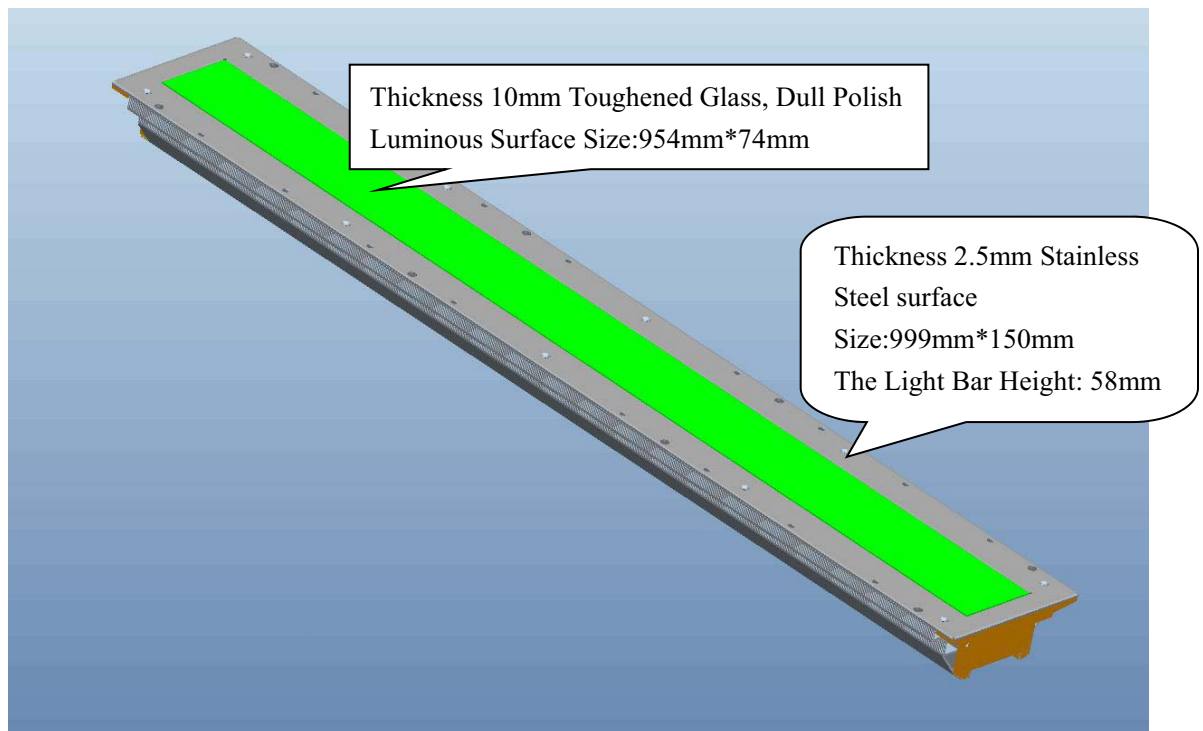

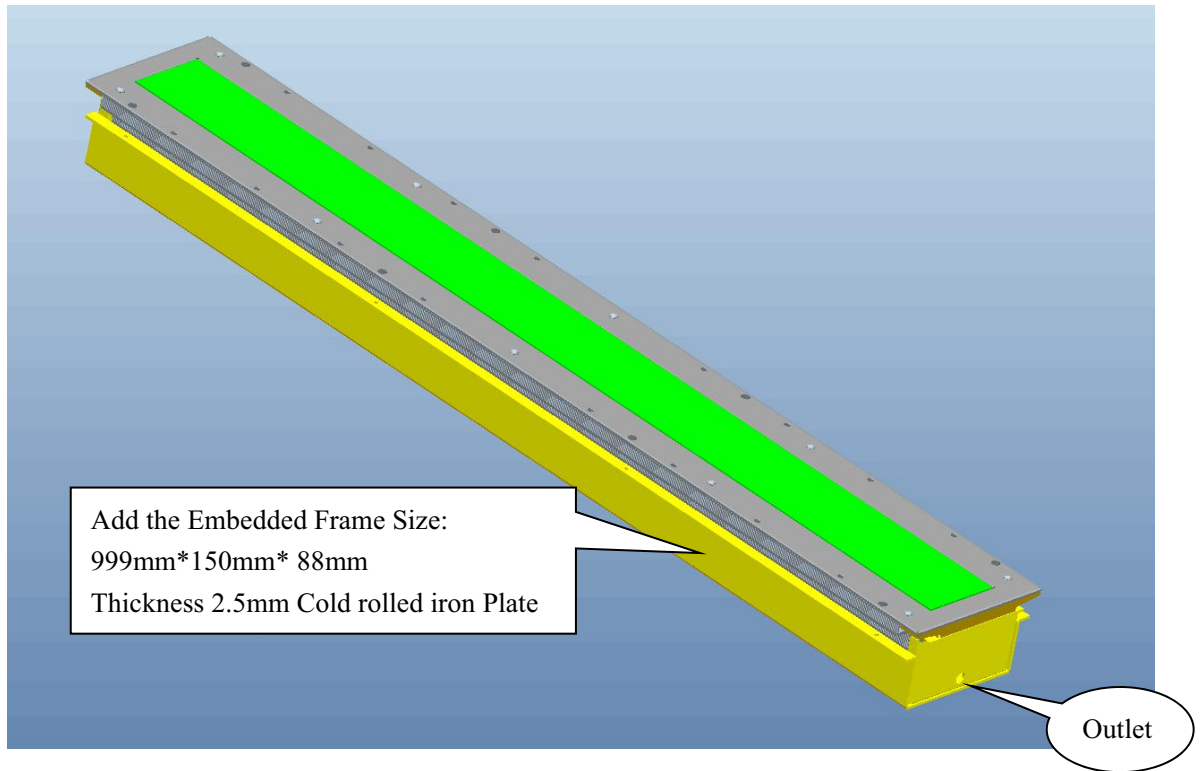

Cross section graph:

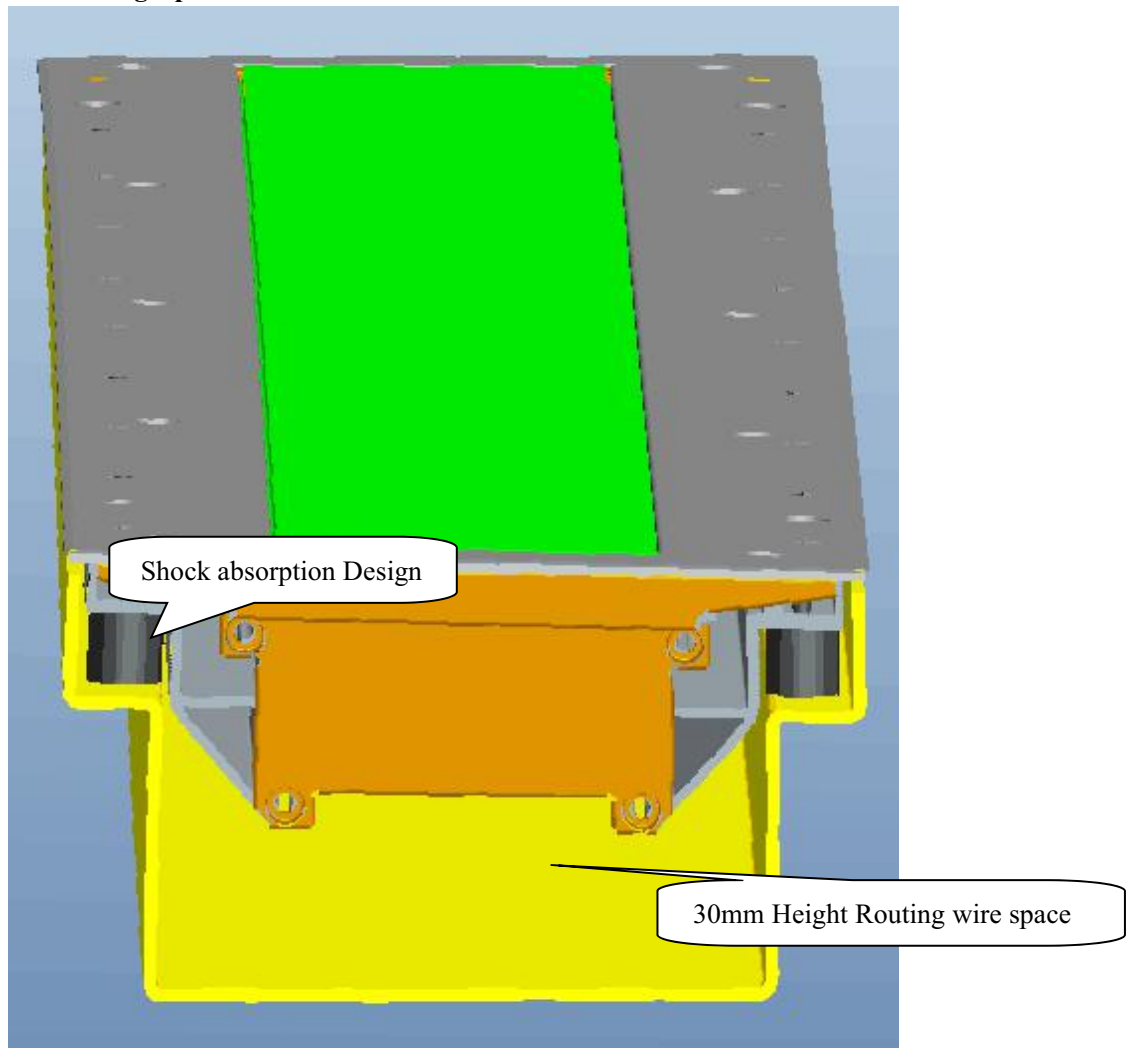

How to connect power supply and light:

Each power supply can connect 2-3 strip light,take electricity from pedestrian light,all power supply are full of glue for waterproof.

Photosensitive are inside the power supply,strips are dimming simultaneously.Day time,brightness 100%,at night,dimming to 25%.

